

# INSTALLATION INSTRUCTIONS

**69-1507TS**  
**HONDA**  
**2018-22 Accord**  
**L4-1.5L Turbo**

**TOOLS NEEDED:**

- Phillips screw driver
- Flat blade screw driver
- 3mm allen ratchet
- Extension
- 10mm socket
- 10mm wrench

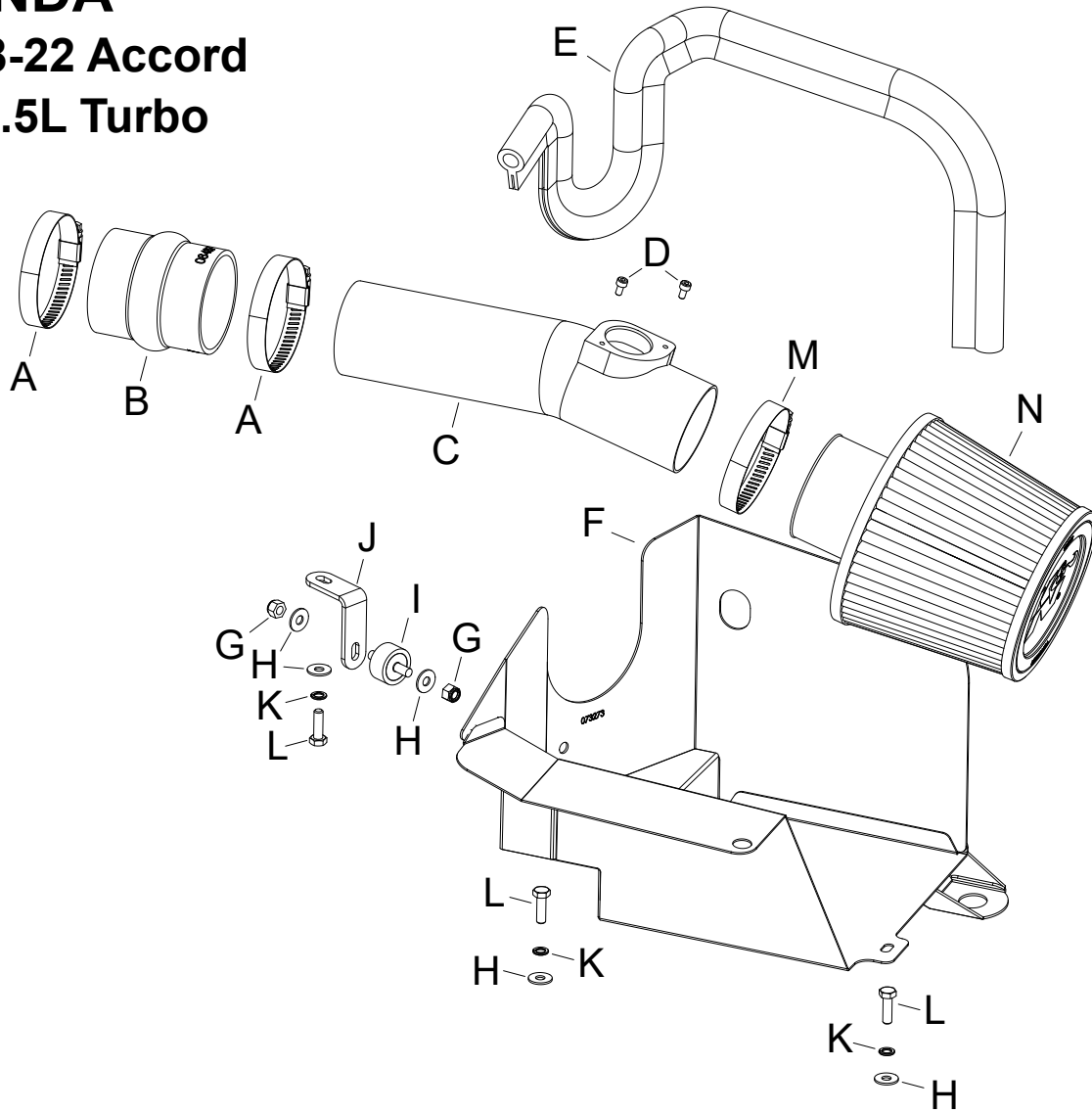

**PARTS LIST:**

Description	Qty.	Part #
A HOSE CLAMP #40	2	08554
B HOSE; HUMP 2.5"ID X 3.125"L	1	08487
C INTAKE TUBE, AL	1	25812S
D BOLT; M4-.7 X 8MM	2	07733
E EDGE TRIM; 30"L	1	102489A
F HEAT SHIELD	1	073273
G NUT; 6MM NYLOCK, HEXHEAD	2	07512
H WASHER; 1/4"ID X 5/8"OD	5	08275
I STUD; M6-1.00 M/M, RUBBER	1	07027
J BRACKET; "L"	1	26517
K WASHER, M6 SPLIT LOCK ZINC	3	1-3025
L BOLT; M6-1 X 16MM	3	07812
M HOSE CLAMP; #40	1	08554
N AIR FILTER	1	RU-5174

If you need any assistance please call 1-800-858-3333 to speak with a representative in our Customer Service Center before returning the product.

**NOTE: FAILURE TO FOLLOW INSTALLATION INSTRUCTIONS AND NOT USING THE PROVIDED HARDWARE MAY DAMAGE THE INTAKE TUBE, THROTTLE BODY AND ENGINE.**

**TO START:**

1. Turn off the ignition and disconnect the negative battery cable.  
**NOTE: Disconnecting the negative battery cable erases pre-programmed electronic memories. Write down all memory settings before disconnecting the negative battery cable. Some radios will require an anti-theft code to be entered after the battery is reconnected. The anti-theft code is typically supplied with your owner's manual. In the event your vehicles anti-theft code cannot be recovered, contact an authorized dealership to obtain your vehicles anti-theft code.**



2. Disconnect the mass air sensor electrical connection.



3. Loosen the hose clamp that secures the intake tube to the turbo inlet pipe.



4. Remove the four pins that secure the fresh air intake to the core support. Remove the fresh air duct from the vehicle.



5. Remove the two bolts that secure the air filter housing and then lift up the intake assembly to remove it from the vehicle.  
**NOTE: K&N Engineering, Inc., recommends that customers do not discard factory air intake.**



6. Install the provided edge trim onto the heat shield as shown, some trimming of the edge trim will be necessary.



7. Remove the mounting grommet from the factory air filter housing and install it into the K&N® heat shield as shown.



8. Install the heat shield assembly into the vehicle and secure with the provided hardware and one of the push pins that originally secured the fresh air intake. Install the three remaining push pins to fill the original mounting holes.



9. Remove the mass air sensor from the factory intake tube and install it into the K&N® intake tube and secure with the provided hardware.



10. Install the provided rubber mounted stud onto the tube mounting bracket as shown using the provided hardware.



11. Install the mounting bracket assembly onto the K&N® intake tube as shown using the provided hardware.



12. Install the provided hump coupler (08487) onto the turbo inlet and secure with the provided hose clamp.



13. Install the K&N® intake tube into the coupler at the turbo inlet and then align the mounting stud with the hole in heat shield. Adjust the intake tube for best fit and then secure with the provided hardware and hose clamp.



14. Install the K&N® air filter and secure with the provided hose clamp.

**NOTE: Drycharger® air filter wrap; part # RX-4990DK is available to purchase separately. To learn more about Drycharger® filter wraps or look up color availability please visit <http://www.knfilters.com>®.**



15. Route the mass air sensor wiring harness through the hole provided in the heat shield and then reconnect the mass air sensor electrical connection.



16. Reconnect the vehicle's negative battery cable. Double check to make sure everything is tight and properly positioned before starting the vehicle.

17. It will be necessary for all K&N® high flow intake systems to be checked periodically for realignment, clearance and tightening of all connections. Failure to follow the above instructions or proper maintenance may void warranty.

#### ROAD TESTING:

1. Start the engine with the transmission in neutral or park, and the parking brake engaged. Listen for air leaks or odd noises. For air leaks secure hoses and connections. For odd noises, find cause and repair before proceeding. This kit will function identically to the factory system except for being louder and much more responsive.

2. Test drive the vehicle. Listen for odd noises or rattles and fix as necessary.

3. If road test is fine, you can now enjoy the added power and performance from your kit.

4. K&N Engineering, Inc., requires cleaning the intake system's air filter element every 100,000 miles. When used in dusty or off-road environments, our filters will require cleaning more often. We recommend that you visually inspect your filter once every 25,000 miles to determine if the screen is still visible. When the screen is no longer visible some place on the filter element, it is time to clean it. To clean and re-oil, purchase our filter Recharger® service kit, part number 99-5050 or 99-5000 and follow the easy instructions.

**NOT LEGAL FOR SALE OR USE ON ANY POLLUTION CONTROLLED MOTOR VEHICLE IN CALIFORNIA OR STATES ADOPTING CALIFORNIA EMISSION PROCEDURES.**

See [knfilters.com](http://knfilters.com) for CARB status on each part for a specific vehicle